



# **2012 Rules and Regulations**

## **General Safety Rules**

**- and -**

## **General Rules**

**Saskatoon Stock Car Racing Association  
(S.S.C.R.A)  
P.O. Box 169  
Saskatoon, Saskatchewan  
S7K 3K4**

**(306) 651-FAST (3278)**

**[www.autoclearingmotorspeedway.ca](http://www.autoclearingmotorspeedway.ca)**

**Effective February 1, 2012**

## **RULEBOOK DISCLAIMER**

The rules and/or regulations set forth in this book are designed to provide for the orderly conduct of racing events and to establish minimum acceptable requirements for such events. These rules shall govern the condition of all events, and by participating in these events, all participants are deemed to have complied with these rules. NO EXPRESSED OR IMPLIED WARRANTY OR SAFETY SHALL RESULT FROM THE PUBLICATION OF, OR COMPLIANCE WITH THESE RULES AND/OR REGULATIONS. They are intended as a guide for the conduct of the sport and are in no way a guarantee against injury or death to a participant, spectator or official.

The race director shall be empowered to permit minor deviation from any of the specifications herein or impose any further restrictions that in their opinion do not alter the minimum acceptable requirements. NO EXPRESSED OR IMPLIED WARRANTY OF SAFETY SHALL RESULT FROM SUCH ALTERATIONS OF SPECIFICATIONS. Any interpretation of, or deviation(s) from these rules shall be left to the discretion of the officials. Their decision is final.

*Saskatoon Stock Car Racing Association*  
(S.S.C.R.A.)

# CODE OF ETHICS

## Purpose

To act in a professional manner so as to bring a positive image to the public and fellow members of the sport of stock car racing and to realize the need for a reasonable and responsible personal code of 'unwritten laws' since laws cannot cover all situations.

## Expectations

1. Respect MUST be had for all traffic laws and criminal codes, such as not drinking and driving.
2. No alcohol, drugs, or stimulants allowed in association with your car or team when in the public eye.
3. No verbal or physical abuse towards any person when connected with a stock car event, display or promotion.
4. When dealing with the public, courtesy and cooperation should be shown to promote the sport in a positive light at all times. For example, do not approach another person's sponsor(s).
5. All members should be clean and presentable when in any public situation.

## Definition of Behavior

Anyone who, by word or deed, impedes, jeopardizes, or in any manner hinders the smooth and orderly presentation of the racing program - or - anyone who commits, or causes to be committed, any detriments to stock car racing, the S.S.C.R.A. will consider that person(s) to have abused the privileges of membership, entry and/or admission granted by the S.S.C.R.A. and that they may be subject to the revoking of those privileges and/or disqualification as deemed proper by the Executive or designated official. Drivers are responsible for the sportsmanlike conduct of anyone in their crew and penalties incurred by a crewmember may affect the driver.

## General Safety Rules

1. **Fire Extinguisher (car):** Optional: every car may have a 2.5lb (1kg) fire extinguisher with a recharge slip back-dated no more than 12 months. The extinguisher **MUST** be mounted securely with a metal quick release mechanism or fire system release cables mounted within reach of the driver with seat belts fastened.
2. **Fire Extinguisher (pit):** Every car **MUST** have a 5lb (2.5kg) fire extinguisher with a recharge slip back-dated no more than 12 months accessible in the pit area.
3. Only left hand drive vehicles may participate in race events. Racing shall take place in a counter-clockwise direction only on the track.
4. In all divisions of stock cars, all welds on the roll cage **MUST** be welded 360 degrees. Joints in major locations (e.g.: door bars, dash bar and roof bars) **MUST** be gusseted. Gussets to be a minimum of 1/8" thick.
6. All cages **MUST** have mandrel-type bends in all corners on main cage and fish mouth joints. No exhaust tube style bends permitted on any cage. No S-bends permitted. All splices and butt joints **MUST** be sleeved. Refer to Diagram B1.
7. No square tubing in main cage.
8. The entire **driver's door area**, which includes the area from the "A" pillar post to the "B" pillar post and from the top door bar to the frame, **MUST** be filled with 1/8" steel plate in such a manner that nothing can pierce the drivers' compartment. If there is no factory kick plate, a steel plate shall replace it. Pieces **MUST** be securely welded on the outside of the door bars.
9. All bars and components that the driver's head or limbs may come in contact with **MUST** be **padded** with a suitable crushable material. No water pipe insulation. The steering wheel center, including OEM steering wheels, **MUST** be padded with a minimum of 2" of approved crushable material.
10. **The ignition switch** in all cars competing **MUST** be labeled in the "OFF" position **must cut power to the motor** and be accessible by the driver when belted up and safety crews from outside the car.
11. All **fuel cells MUST** have a ground strap. Fuel caps **must** have a ground strap.
12. **Automatic Transmission:** Any car in any division with an automatic transmission **MUST** have a neutral safety switch, which may be routed through the brake light switch.
13. The **drive shaft MUST** be painted white. Removable **ballast** used in cars **MUST** be painted white and marked with car number.
14. No anti-freeze allowed in any car/truck on the track. Use of Water-Wetter for lubrication is permitted.
15. **Seat Belt**
  - a) Every car **MUST** be equipped with a 5-point quick release seat belt. Shoulder mounts **MUST** be mounted level with the shoulder to four inches below shoulder and in accordance with manufacturer's instructions. Seat belts to be anchored to the seat mount and/or roll cage at a 45-degree angle with reference to the floor of the car. Crotch strap to go through the seat and anchor behind the driver's chest line. All belts **MUST** be mounted to the seat mount and/or roll cage. See diagrams C1, C2, C3, C4, and C5.
  - b) Minimum 2" wide belts are mandatory in all divisions. All belts **MUST** be clearly labeled and dated by the manufacturer. Systems **MUST** be updated at 4-year intervals from the date of manufacture in Super Late Model division and Western Elite, 5-year intervals in all other divisions.
  - c) Seat belts will have to be changed prior to the prescribed frequency if they exhibit wear or fraying of the fabric.
  - d) Seat belts must be worn at all time on the track.

16. **Window Net:** Every car **MUST** be a quick opening type from an approved manufacturer, equipped with a **TIGHT** driver's side window net. Net **MUST** be web style and quick opening, complete with mounting rods composed of minimum 3/8" steel rod. Attaching points **MUST** be of equivalent strength and mounted to roll cage. Window nets must be 'up' at all time on the track. Super Late Model and Mini Stock check for added addendums in your divisional rules.
17. **Racing Suit:** All drivers **MUST** wear a minimum single layer certified racing suit. Super Late Model and Siemens West drivers **MUST** wear a two-layer certified racing suit. A single layer certified racing suit with full Nomex underwear is acceptable as two layers. Racing suits exhibiting excessive wear or abuse must be replaced.
18. **Helmets** for all divisions **MUST** meet Snell-SA2000 specifications or equivalent. It is recommended that if purchasing a new helmet, Snell-SA/2010 be purchased. Half-shell helmets are not permitted. Full face, Snell Automotive Sports (SA) design helmets are recommended. Fire retardant balaclava recommended.
19. **Mass produced head and neck restraint systems mandatory** in all divisions. A neck collar does not qualify as a head and neck restraint system. **Exception: for the Enduro and Street Stock Invitational the minimum requirement will be a neck collar.**
20. **Eye protection mandatory in all divisions.**
21. **Fire retardant driving gloves are mandatory in all divisions. SFI certified racing shoes are mandatory in all divisions.**
22. **Lights (Optional):** All cars in competition may have lights illuminated for night racing. Two red tail lights and two amber front lights **may only** be located at the extremities of the body. Lights to be 2" in diameter (or equivalent size). Additionally, the Thunder Stock division may add two red tail lights mounted in the rear window. It is recommended that all lighting systems be fused at the light switch. Lights are limited to those listed. Additional lights including brake lights are not permitted.
23. When a collision or rollover occurs, **ONLY THE SAFETY CREW WILL BE ALLOWED NEAR THE CAR.** The ambulance crew or first aid attendants will first determine whether to remove the driver from the car before righting it. (There is a chance of serious injury to the driver when being removed if internally injured.) The tow truck will move the car to right it. All drivers in competition **MUST** remain in their cars until the race is completely stopped. Anyone finding that for any reason he/she cannot continue to race should leave the racing surface to avoid jeopardizing themselves or other competitors.
24. The officials or the flagman may disqualify cars containing loose objects or any other items that could be a detriment to other competitors.
25. **Speed limit** in the pit area, including the staging area, is 5 mph (8 kph). No excessive wheel spinning. Violators are subject to a fine.
26. Any safety violation will result in a one-race meet suspension and/or fine, pending discretion of Competition Committee.

## General Rules

1. All people in the competition area **MUST** be members of the S.S.C.R.A. except as provided. All persons entering the competition area including officials **MUST** sign a release waiver. No one under the age of 12 years is allowed in the pit area during competition. Anyone under 18 entering the pit area **MUST** have parent's written permission to enter pit area during competition.  
Junior members under the Junior Racing Program will be permitted entry to the pits at 12 years of age. Actions and behaviour of junior members will be monitored. Pit entry privileges may be revoked if warranted.
2.
  - a) ACMS reserves the right to limit pit entry to **eight** people, including the driver, with each car per race night.
  - b) Entry to the pits will be granted once the back gate fee has been paid and waiver signed. Only season ticket holders will be allowed to use these tickets for back gate entrance. Flex tickets, two for one, free or other promotional tickets will **NOT** be accepted.
  - c) Back Gate will be closed at one half hour before the scheduled start time on that given event. Once gate is closed, pit crews or driver must enter from fan side. See Fan Side Manager for entrance and signing of waiver.
3. It is the driver's responsibility to inform their crew of the rules and regulations. Fines will be levied against the car.
4. **Dress Attire:** No person shall be admitted to the pits unless they are appropriately dressed: minimum knee length shorts or full length pants, shirt with minimum three inch sleeves and full shoes (no sandals). Any person dressed improperly, will be asked to leave the pits for the remainder of the race meet.
5. **Officials** to wear club colors or uniform.
6. Pit crew and driver clothing **MUST** be clean. Violators are subject to a fine.
7. Cars will not be allowed to compete unless they are towed to and from the track unless street legal. Anyone caught driving a racecar on public roads will be fined \$25.00 for the first offense and \$40.00 for the second offense and be suspended from the S.S.C.R.A.  
**Racecars MUST be unloaded at the track before the back gate closing time scheduled on race day. All race cars must remain in the pit area until the final race of the program has finished. Cars may enter and leave at other times by permission of the Pit Marshall only.**
8. The S.S.C.R.A. reserves the right to ask for medical proof of health.
9. Drivers without a valid driver's license may apply to the Executive for approval to compete. Anyone under 18 years of age **MUST** have his/her parent's written permission to race. If a driver's license is revoked, only the S.S.C.R.A. Executive can make reinstatement to race.
10. **Transponders:** All cars/trucks in competition must have a transponder compatible with the track automated timing system. Transponders will be available for rent at the back gate each race day for a fee approved by the Executive. Rental transponders must be returned at the end of each race meet. Drivers will be responsible for any lost or damaged transponder. Transponders not returned after evenings race program will result in a possible penalty. **Mounting location will be determined by Tech Committee.**
11. **Radios or receivers:** No radios or receivers of any kind allowed in competition, unless permitted in division rules or issued by SSCRA. Raceceivers are mandatory in all divisions Starting in 2011, it will be mandatory for each race team to have a receiver with only capabilities of one way communications which will be receive only. This receiver must be programmable to a frequency given by the track officials. In divisions which radios are allowed, either spotter or driver must have the capability of receiving this said given frequency at any given time. Spotter with this device must have direct communication with

their driver. If the spotter does not relay the information to the driver in a timely manner the car will not be scored. Divisions not allowed radios **WILL NOT BE ALLOWED** to use the raceceivers to communicate with their driver.

12. In Divisions where radio communication is allowed, only the spotter that is in radio contact with a car currently racing will be allowed on an elevated platform. Any platform that is more than 24 inches above ground level must have a 42 inch high guard rail on all sides. Only properly designed platforms will be allowed. i.e. no standing on tires, chairs, etc.
13. No vehicles, other than the cars competing and track service vehicles, will be allowed in the pit area during competition.
14. All cars **MUST** provide at least one representative after each race meet for the work party or the prize money is forfeited. Alternate jobs may be designated.
15. Any **car left in the pits** over 24 hours will be considered abandoned and become property of the S.S.C.R.A.
16. **Track Record:** Permission **MUST** be granted one week prior to an attempt to set a track record. The time trial will be held one half hour prior to the race event start time. The car/truck must immediately report to tech following the record attempt. If a track record is set during scheduled time trials, the cars/truck will be waved to tech. No track record will be awarded until the car/truck passes technical inspection.
17. **Displays:**
  - a) Any displays involving more than one member and car **MUST** have the approval of the S.S.C.R.A. Executive or the Advertising and Promotions Committee.
  - b) No one is allowed to use the Bridge City Speedway Inc., Auto Clearing Motor Speedway or S.S.C.R.A. credentials, which are the property of the S.S.C.R.A., without the permission of the S.S.C.R.A. Executive.
  - c) Any violation of this rule may result in suspension.
18. **Trophy Awards:**
  - a) **"Rookie of the Year":** Rookie of the year trophy will be awarded to the eligible driver who has the most points. Eligible drivers being anyone who has not competed in more than 3 race days in that division in any previous year. Rookie status drivers can move upward in divisions from Thunder stock to Street stock to WEST to Super Late Models, but cannot move down. Rookies **MUST** register on driver's application forms at the start of the year so executive can review qualifications. If anyone other than the registered rookie driver races the car during the year, the race director **MUST** be informed and rookie eligibility will be forfeited.
  - b) **"Most Improved Driver":** Most improved driver will be voted on by the drivers in each division by ballot.
19.
  - a) In the event of behavior unbecoming of an S.S.C.R.A. member (not complying with the Associations' set Code of Ethics), the Executive will review the privilege of membership. The Executive will decide if censure, written warning, probation, suspension, or revocation of membership is to follow.
  - b) Any actions felt to be intentional to harm a competitor's car in non-competition will result in suspension and/or fine.
  - c) Any action felt to be intentional to harm a fellow member will result in either expulsion, suspension and/or a fine.
  - d) Any verbal or physical altercations in the public eye will result in suspension and/or a fine.
20. **Swearing, abusive or ungentlemanly conduct towards or any Association official is subject to an immediate suspension of two race meets and/or a fine. Any physical contact will bring an automatic one-year suspension from the S.S.C.R.A. from the date of the offense. All S.S.C.R.A. members are responsible for their own fines and the fine is to be paid before the next race day or the offender will be refused pit entrance.**

21. ALL persons in the competitor area are not to be under the influence of or in the possession of stimulants, illegal drugs or alcohol proceeding, during or after a race. Offenders will be suspended for two race meets for the first offense and for the remainder of the season for the second offense. Breathalyzer and urine samples may be requested and refusal to comply will result in a three race meet suspension.
22. All rulings made by the S.S.C.R.A. Executive are final. If one of the Executive is being protested, they **MUST** step down while the matter is handled by the rest of the Executive.
23. Notice of infraction of any of the rules may be issued by any Race Official. Where provided, fines and/or discipline is automatic. Where a fine or discipline is not defined in these rules, the matter will be decided by the Competition Committee or the Ethics Committee as appropriate.
24. **The right of appeal** is given to any member of the S.S.C.R.A. who has been disciplined for any infraction of rules, regulations, or specifications of the S.S.C.R.A. with the exception of a black flag.

The appeal must be filed in writing by the Wednesday following the notice of discipline. The appeal will be heard by the next Wednesday and a decision rendered before the next race meet. The Appeal Committee will consist of the President, the First Vice-President and the Second Vice-President. The Appeal Committee shall select a Director to act as an alternate in the event one of the above must stand down due to a conflict of interest.
25. All vehicles entering or leaving the pit area **MUST** do so at the designated area on the back straight.
26. Burnouts on the race surface will result in a minimum \$25.00 fine.
27. Car Numbers:
  - a) All numbers are assigned and are property of the S.S.C.R.A.
  - b) Car numbers will be limited to a maximum of two digits.
  - c) If a current member has a number for that year, they retain that number next year, providing they register their car by opening day. or if they miss the next year, they may have that year as a grace period. If they return the following year prior to race season opener with a registered car they would retain the number. If not, they lose rights to it.
28. **Identification numbers** must be clearly legible and **MUST** appear on both doors at least 18" high with a two inch stroke. An 18 inch by 18 inch number with a two inch stroke **MUST** be on the passenger side roof of the car facing out the right. All car numbers will be limited to a maximum of two digits. Cubic inch displacement in metric or imperial and make of car **MUST** be on the front of the car. Car number **MUST** also be on rear of car, a minimum of four inches high. If a number cannot be read from the flag stand or main tower, it will have to be changed.
29. **Out-of-town and non-registered** cars **MUST** change their car number for that specific race day if their number conflicts with a local car number. **No letters or three digit numbers allowed.**
30. The top portion of the windshield in all divisions is reserved by the SSCRA for club and/or division **sponsorship banners**. No marking or decals are to appear below the banner.
31. No rear **window louvers** allowed. Front and rear windows must be unobstructed and kept clean.
32. **Tow hooks** or straps are mandatory on the front and rear of each Thunder car. Tow straps are required for all other divisions.
33. All cars competing, whether from different tracks or previous years, **MUST** comply with the current S.S.C.R.A. rules.
34. Visiting cars DO NOT receive local points.
35. **Driver changes** during the event may occur going up, down, or within a division as long as the race director gives permission. The car **MUST** start at the rear of the lineup for the

remainder of the event. All points go to the registered driver/car combination. In case of medical reasons or a scheduled absence, the race director may approve a replacement driver with points going to the registered driver/car combination. The car **MUST** start at the rear of the lineup for the entire event unless the replacement driver is the alternate driver originally listed on the car registration form.

36. The responsibility for knowing which race and what position to be in rests with each car's crew.
37. **Late for line-ups:** Any car late for a lineup will be placed at the back of the lineup. Exceptions are at the Race Director's or Pit Marshall's discretion only.
38. One crew member **allowed** per car/**truck** in the staging lane. **Crew member to remain positioned at the left side of the car/truck.**
39. No working on the car in the staging lane. Exceptions only at the Race Director's or Pit Marshall's discretion, including refueling. Only Super Late Model and **Western Sportsman** cars will be allowed to adjust tire pressures prior to entering the race track. Anyone holding up advancement post-staging will be put to the rear of the field. Portable air tanks only will be allowed on staging lane. No exceptions.
40. Some races may be designated as using the staging lane as 'hot pits'. The hot pits are separated from the main pits by the concrete barrier. No crew member may go over the barrier into the hot pit until their **car has come to a complete stop. No more than three crew members in the hot pit at any time.** The car may not leave the hot pit until all their crew members are back over the barrier.
41. The Competition Committee will make up race day schedules and reserves the right to alter the race schedule during the event to accommodate unforeseen circumstances.
42. **The flagman is in complete charge** during the race. He has the authority to disqualify any cars obstructing the race as he sees fit.
43. While a race is in progress, **NO ONE** will cross the track.
44. The **Start/Finish line** will be the center of the front straight.
45. **Flags:**

**Green:** The waving of the green flag signals the start of the race. A rolled up green flag displayed during warm up laps indicates the race will start on the next lap (green light).

**Yellow:** CAUTION – Indicates an incident has occurred that is a hazard to the cars/drivers in the race. The caution flag will be given to the first car passing under the flagman. Restarts are determined by the last completed green flag lap. Laps are turned on and off by the leader of the race. Any car involved in an accident will start at the rear of the field. Cars pitting while the race is under caution will rejoin the field at the rear (yellow light).

**Red:** Indicates drivers are to stop even with and to the right of the flagman displaying the red flag (red light).

**Note:** All work must stop on any car participating in the current race in the pits while the track is under a red flag condition. Work may not commence on any vehicle entering the pits while the track is under a red flag condition. Once the red flag is lifted, work may commence or resume on cars in the pits. No car may enter the track while the track is under red.

The penalty for working on a car while the track is under red is a one green lap penalty. The car will be held at the track entry for one full green lap when it is ready to re-enter the race. It is the responsibility of the pit crew to know what color the track is under.

**Black:** A rolled up black flag pointed at any car during a race serves as a warning that an infraction of the race rules has occurred. An open black flag directed at any car means the car must immediately leave the race and report to your pit. The Pit Marshall will give explanation of penalty.

- a) An open black flag during a caution, the flagperson will either point you to the back of the line or point you into the pits.

- b) For all open black flags, your car number will be flashing on the scoreboard. You have three laps to leave the track and report to the Pit Marshall. After three laps, disqualification from the race is automatic and you will no longer be scored for the balance of the race.
  - c) If you receive 3 black flags for that race event you will be disqualified for the remainder of that race event
  - d) Any car disqualified from a race will start at the back of the pack for the balance of the evening or the first race of the following event if disqualification was in the feature
- Black with yellow dot:** Indicates a mechanical or structural problem with your car that is a hazard to yourself or other cars in the race. You must immediately report to your pit to have the problem corrected. The car may not re-enter the race until cleared by your division's technical inspector or a race official. Your car number will be flashing on the scoreboard. You have three laps to leave the track. After three laps, disqualification from the race is automatic and you will no longer be scored for the balance of the race.
- Blue:** Indicates you are being lapped and must hold your groove, permitting cars to pass uninhibited. You may also be blue flagged if your are purposely blocking or obstructing cars from passing.
- White:** Is displayed to the leading car and indicates one lap remains in the race.
- Checkered:** Is displayed to the leading car and indicates the race is complete.
- Checkered and Yellow:** Indicates the race is complete but an incident has occurred on the track after the checkered flag was displayed. Race to the finish, but proceed with caution (green and yellow lights).
- 46. A **race is deemed complete** after 50 percent of the announced laps have been completed if a race needs to be halted before race length is completed.
  - 47. **First lap caution:** In the event a caution is necessary before the first lap is complete, there will be a restart based on the original starting lineup. The car(s) that caused the caution will be placed in the lineup at the flagman's discretion. The flagman, at his/her discretion, may allow only one restart under the original starting lineup per race.
  - 48. Any car responsible for more than one restart will be disqualified from the race. Any car disqualified from a race for any reason will start from the back of the lineup for the balance of the race day. Any disregarding of the flags will result in a fine and/or suspension.
  - 49. If you are running under a caution flag, you **MUST** get the green, white and checkered flags, before the race is complete.
  - 50. A penalty of \$25.00 will be issued to anyone who inquires about race results before posting. Any attempt to destroy or impair tower official's capacity for collected thought or decisive action will result in a \$25.00 fine.
  - 51. **Technical Inspections:**
    - a) ALL cars competing **MUST** go through tech inspection **BEFORE RACING**. Car **MUST** be checked on a designated tech day, otherwise a \$25.00 fee will be charged for a non-scheduled tech inspection. No initial teching on race night for non-teched cars.
    - b) The driver/owner of the car is responsible to make their car conform to local rules.
    - c) All Tech equipment that is owned and used by the SSCRA Competition Committee will be considered FINAL, no protests will be accepted!
  - 52. If you have a problem not specified in the rulebook, contact the Technical Inspector for your division and receive a written opinion.
  - 53. **Omission of any technical/mechanical rule does not imply it is legal.**
  - 54. **Post Race Technical Inspections**
    - a) The tech committee reserves the right to tech the top five finishers of the feature events, or any other car, at any time. Refusal of tech or protest will result in immediate suspension of the car and number for the remainder of the year. All illegal parts will be confiscated and auctioned off at the end of the season.

- b) Any car finishing in the top five positions of a feature race that does not report to the technical inspection station immediately on leaving the race track will be disqualified.
  - c) Anyone caught tampering with seals on a sealed crate engine or otherwise cheating with a sealed crate engine in any division will be subject to a one year suspension and the engine confiscated as above.
55. **Scales:** The scales owned by the S.S.C.R.A. when used in the locations permanently marked on the inspection pad at Auto Clearing Motor Speedway are the benchmark and will determine the actual weight and weight percentages of all cars.
56. a) If a car is found to be illegal, that car will lose the points and money earned at that race meet plus 15% of the total points to date. For a second offense, the car will be penalized as above and additionally receive a two race meet suspension
- b) Any car that fails the weight and/or measurement requirements for their division will lose any points and/or prize money earned for the race where the infraction occurs.
57. **Noise Levels:** All cars competing **must have a muffler** and will be subject to a maximum noise level of 98 decibels. Noise level in stands will be taken at a designated location with a decibel meter owned by the S.S.C.R.A. This meter will be the standard for all cars. Cars/trucks not meeting the standard will have no more than one race meet to standard. If no action is taken to conform to the rule, the offending car will not be allowed to compete until correction is made. Decibel readings will also be taken in the pit area.
58. It must be recognized that Auto Clearing Motor Speedway is in a jurisdiction that has a **noise bylaw**. Procedures will be in place to limit individual races that extend beyond a reasonable time to ensure all racing is complete by 10:00pm, unless an extension has been specifically granted by the RM for that date.
59. The SSCRA Competition Committee reserves the right to in the Spirit of Competition to add devices to any vehicle to equal competition.
60. **All protests** on your finish position **MUST** be submitted in writing to the Competition Director by the Wednesday immediately following a race event.
61. **Protest:** A car driver may file a protest against a single car within their division. Only one car protest per race event is allowed. All protests **MUST** be submitted to the Competition Committee, Race Director or Pit Marshall within 15 minutes of the conclusion of the final race. Protests **MUST** be submitted on the official protest form available from the competition committee. All protests to be written, signed by the driver, and accompanied by the required fee (cash). The fees will run as follows:
- a) \$100 Chassis and suspension inspection **or**,  
Cylinder head, intake, camshaft, exhaust, and carburetor (top end) inspection **or**,  
clutch, transmission and differential ratio inspection.
  - b) \$200 Cylinder head, intake, camshaft, exhaust, carburetor, oil pan one connecting rod, piston and crankshaft.
  - c) \$250 Dyno test of horsepower only of a sealed crate engine in applicable divisions. This is a service only and no monies will change hands whatever the outcome of the test results is. Monies are non refundable!
62. There **MUST** be one spokesperson from the protesting car present during any dispute or tear down of the vehicle.
63. New: In the event of a **sealed crate engine failure**, the following procedure will be enforced.  
A **supervised** engine inspection will be performed by a member of the Competition Committee. The installation of engine components must be supervised and **SSCRA seals** will be installed. **ALL components must be Genuine to the Manufacturer specifications for that engine and proof of component part numbers must be provided to the inspector.** In the event of “any” machining must be done (resurfacing block or cylinder head), the engine part must be replaced. **All costs of travel** for the inspector will be covered by the individual who requests this ser

# Saskatoon Stock Car Racing Association Protest Form



Race Date: \_\_\_\_\_

Division:

- |                                            |                                        |
|--------------------------------------------|----------------------------------------|
| <input type="checkbox"/> Super Late Model  | <input type="checkbox"/> Thunder Stock |
| <input type="checkbox"/> Western Sportsman | <input type="checkbox"/> Mini Stock    |
| <input type="checkbox"/> Street Stock      | <input type="checkbox"/> Pro Truck     |

---

**Protest Against (Name):** \_\_\_\_\_

**Protest For:** \_\_\_\_\_

**Reason for Complaint:** \_\_\_\_\_

\_\_\_\_\_  
\_\_\_\_\_

**Protest Fee:**

- \$100 – chassis and suspension inspection or, cylinder head, intake, camshaft, exhaust and carburetor (top end) inspection or, transmission and differential ratio inspection.
- \$200 – cylinder head, intake, camshaft, exhaust, carburetor, oil pan, one connecting rod, one piston and crankshaft
- \$250 – Dyno testing of sealed crate engine for horse power rating only

**Protester's Name:** \_\_\_\_\_

**Protester's Signature:** \_\_\_\_\_

---

**Cash Collected By:** \_\_\_\_\_

**Technical Inspector/  
Race Director Signature:** \_\_\_\_\_

---

**Protest Results:** \_\_\_\_\_

\_\_\_\_\_  
\_\_\_\_\_

---

⇒ **Protest forms must be turned in to the Technical Inspector or Race Director 15 minutes after the conclusion of the final race.**

⇒ **All teardowns will be arranged with all parties.**

Appendix A

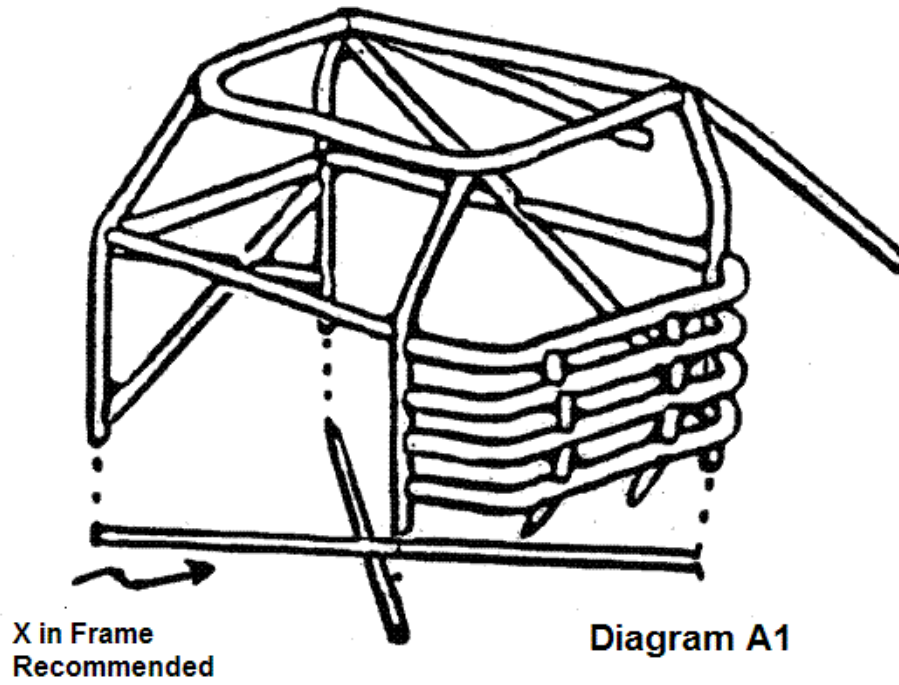

Figure A1

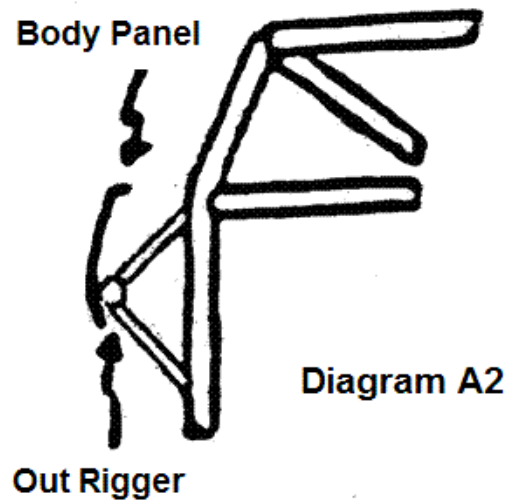

Figure A2

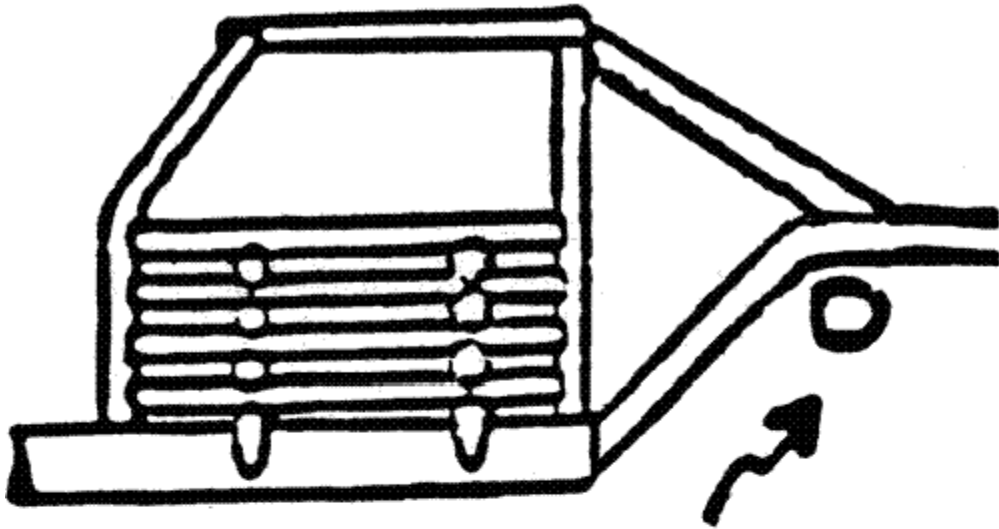

Diagram A3

Differential

Figure A3

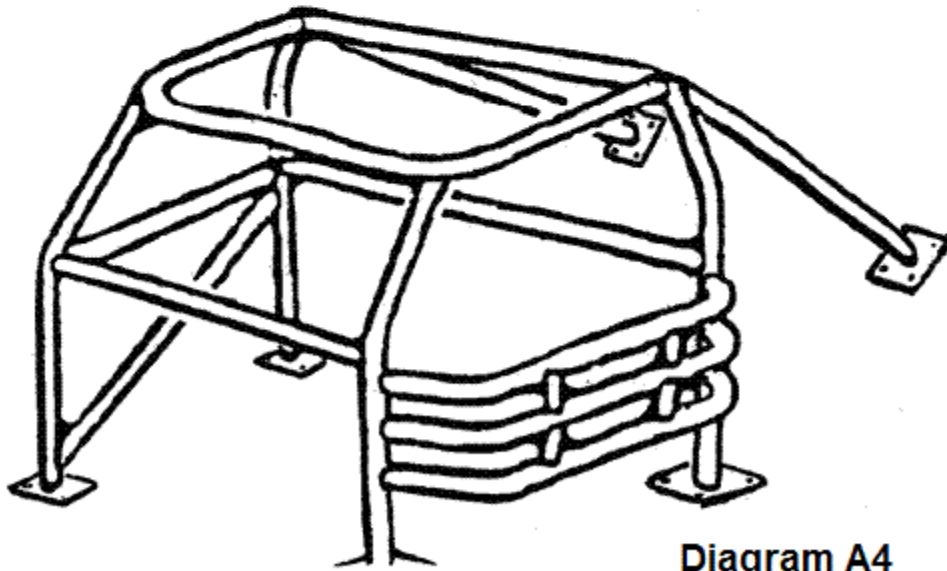

Diagram A4

Figure A4

## Appendix B

### Diagram B1

Acceptable method of splicing tubing structure

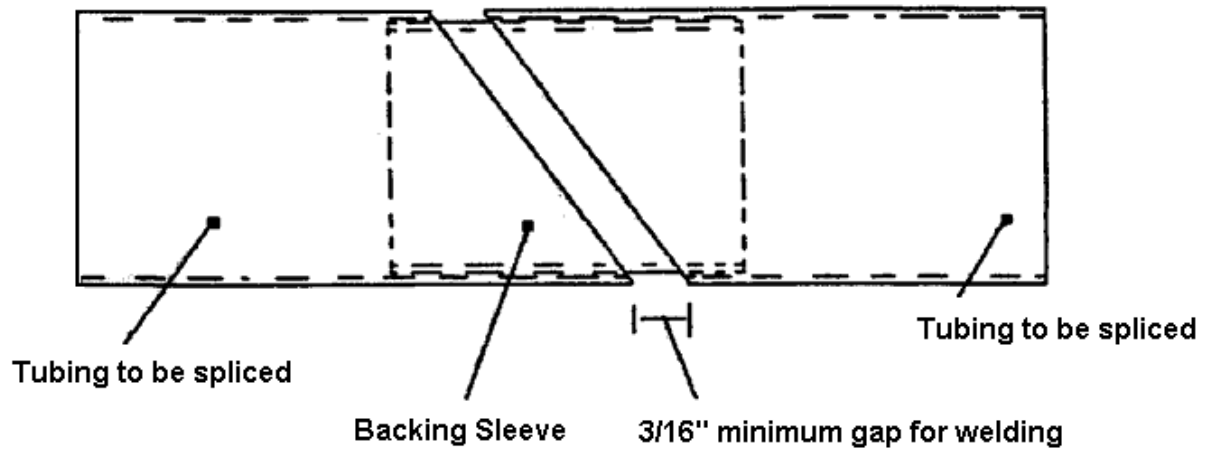

Figure B1

Tubing supported bumpers or covers

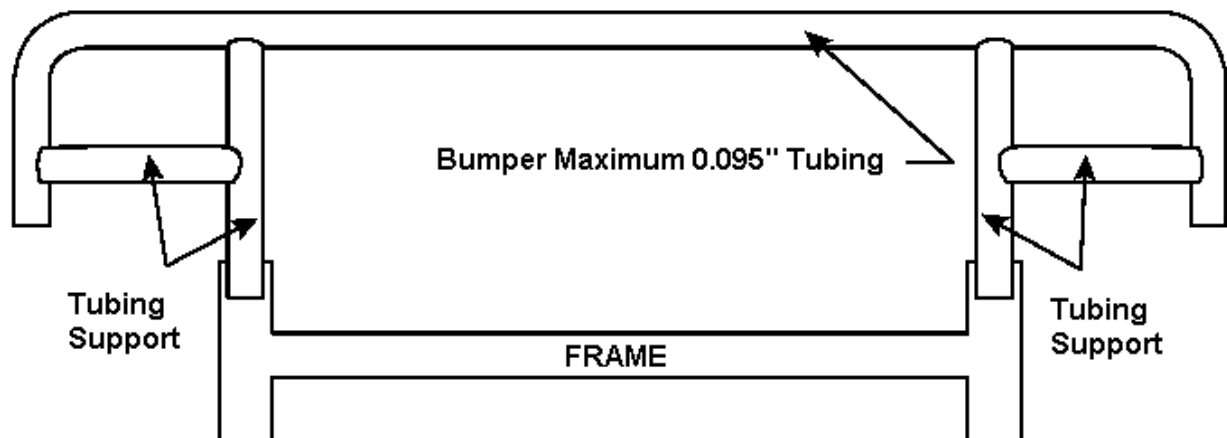

Figure B2

## Appendix C

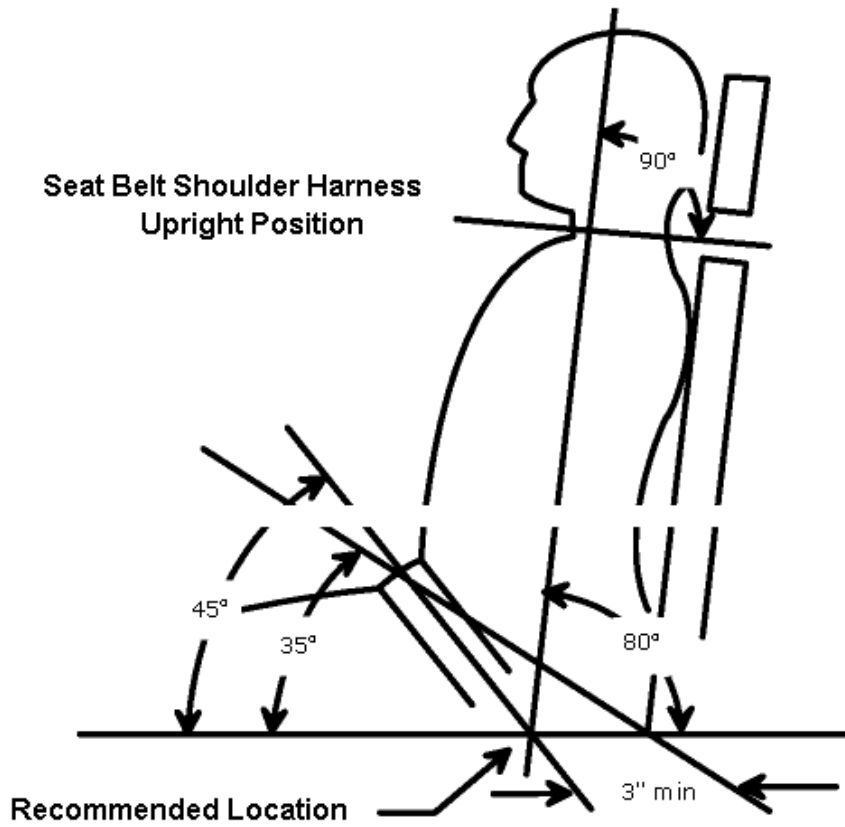

Figure C1

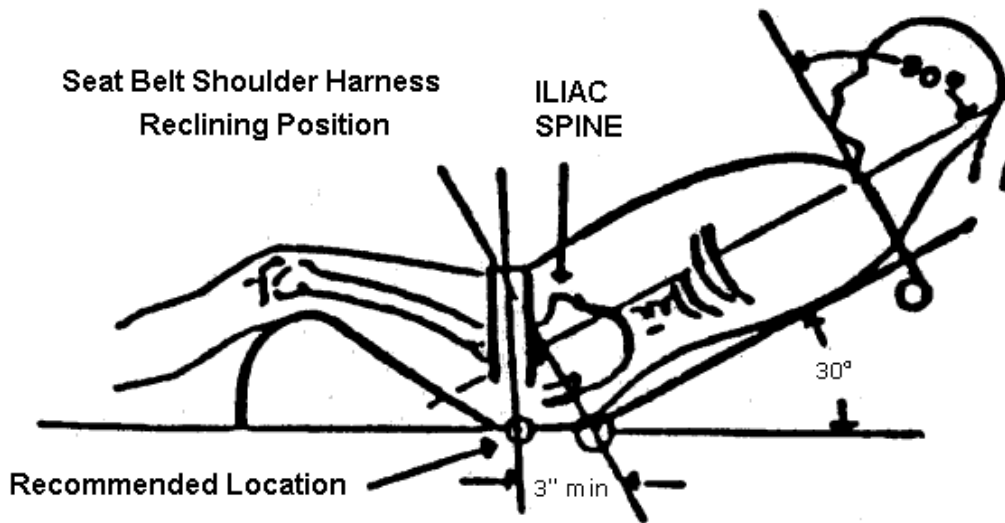

Figure C2

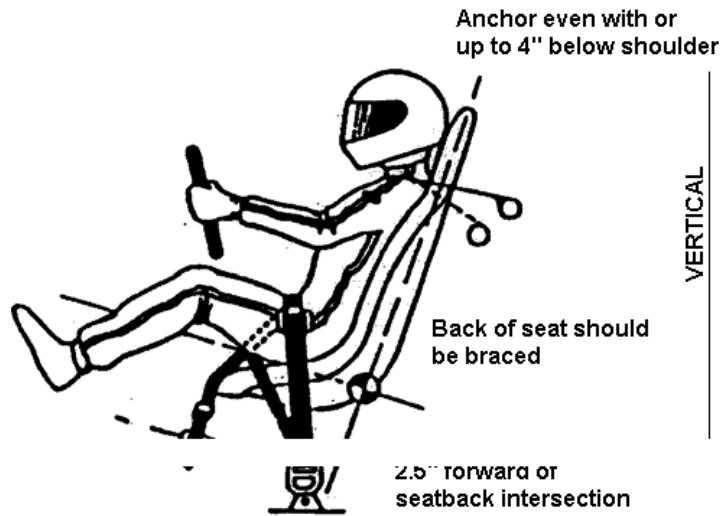

Figure C3

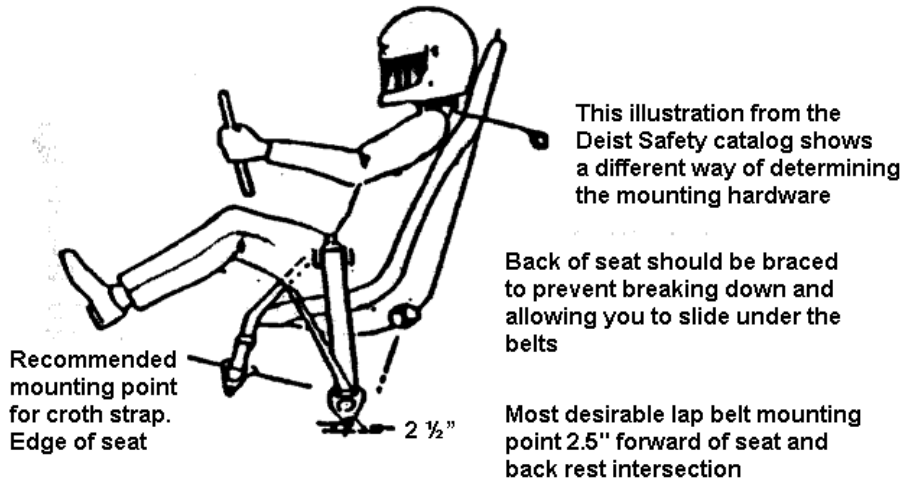

Figure C4

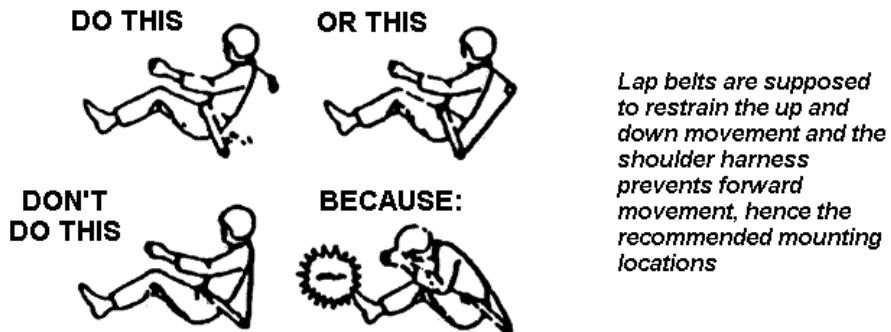

Figure C5

# ROLL CAGE

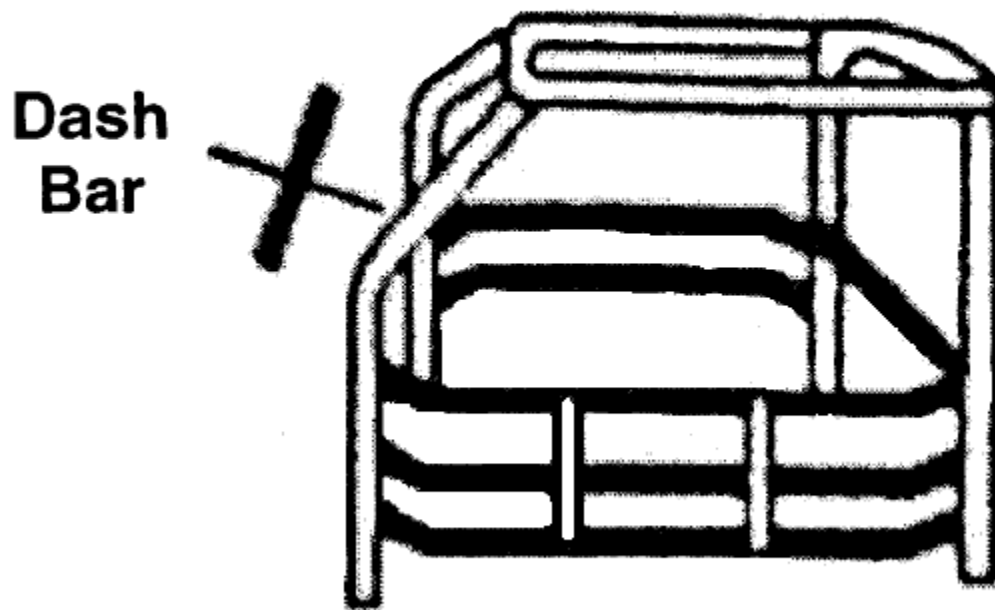

Figure D1